

NOTE: LINE SHOWS ORIGINAL SPRING PIVOT

NOTE: REAR SPRING HANGER SWITCHED LEFT TO RIGHT AND VICE VERSA- TOP MOUNTING HOLES REUSED

NOTE: KIT DOES NOT INCLUDE BOLTS ETC TO SECURE THE NEW CROSSMEMBER OR BRACKETS TO THE CHASSIS, OR TO ASSEMBLE THE CROSSMEMBER AND PANNARD ROD BRACKETS.

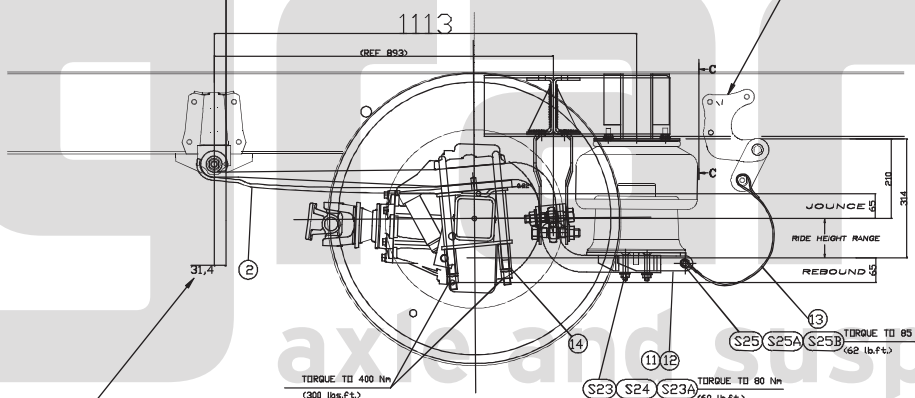

NOTE: CONVERTER MUST REPOSITION ORIGINAL SPRING HANGER AS DIMENSIONED FORWARD OF ORIGINAL POSITION, TAKING THE INTERNAL CROSSMEMBER WITH IT

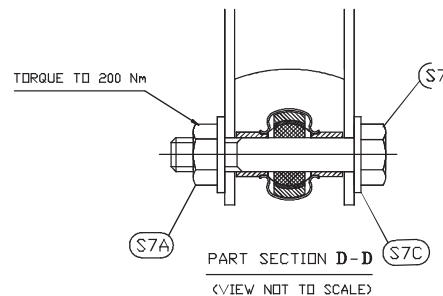

NOTE: PARTS S13A & S13AA NEED TO BE LUBRICATED USING SUPPLIED GREASER S13G WITH: SHELL ALVANIA No.2, AEROSHELL GREASE No.4(DTD577) OR EQUIVALENT. GREASER S13G SHOULD BE SUPPLIED TO END USER TO GREASE AT EVERY SERVICE OR MINIMUM OF EVERY 15000KMM

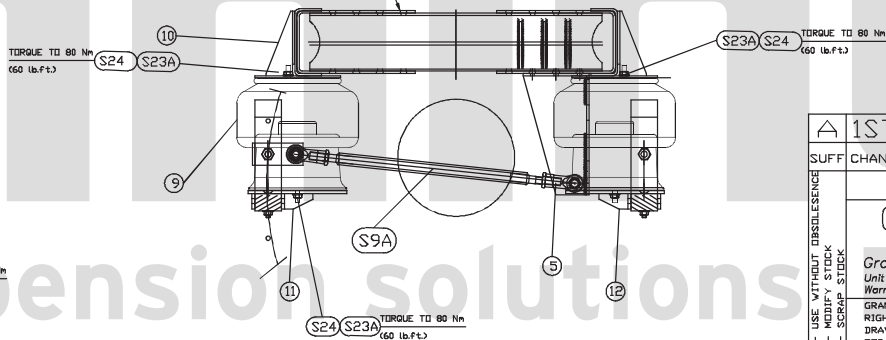
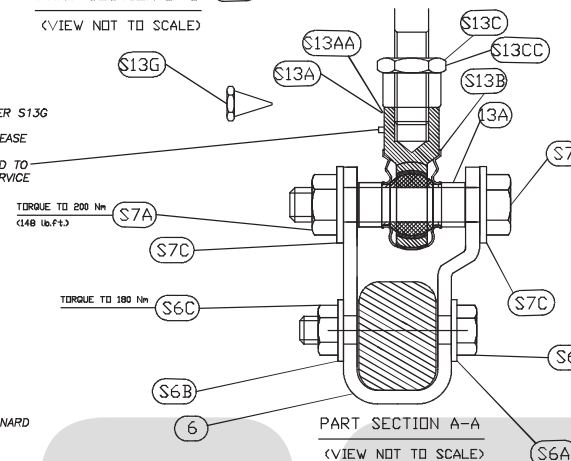

ITEM	PART NO.	QTY	DESCRIPTION	NOTES
BILL OF MATERIALS				
DRAWN BY P SLATOR			AUTHORISED MPQ	
DATE 24 OCT 11			CHECKED MPQ	
ALL ALTERATIONS TO BE VIA CAD			SCALE	
ESTIMATED ACTUAL			SUPERSEDES	

△ 1ST ISSUE	- DCN11/505	PS	24 OCT 2011
SUFF CHANGE & REASON	DISP	ORIGIN	BY DATE

<p>MODIFICATIONS</p> <p>GRANNING LYNX</p> <p>Granning UK Ltd. Unit 37, Mellord Court, Hardwick Grange, Warrington, Cheshire, WA1 4RZ, England.</p> <p>GRANNING UK/GLD LTD. CLAIMS PROPRIETARY RIGHTS TO ALL INFORMATION DISCLOSED ON THIS DRAWING. IT IS NOT TO BE REPRODUCED OR USED FOR MANUFACTURE OR FOR ANY OTHER PURPOSE OR DISCLOSED TO ANY THIRD PARTY WITHOUT OUR WRITTEN PERMISSION.</p>
MATERIAL
FINISH
TITLE SUSPENSION INSTALLATION ISUZU N SERIES
DRAWING NO. 18307
SHEET 1 OF 1

<p>DO NOT SCALE IF IN DOUBT ASK</p>	<p>DESIGNED FOR ISUZU N SERIES RASIE/ LOWER</p>
<p>ALL DIMENSIONS ARE IN MILLIMETRES</p> <p>ORIGINAL FRAME SIZE 562mm x 390mm</p>	<p>COMPONENTS TO CARRY PART NO. _____ AT LOCATION (P) BATCH DATE _____ (B) SUPPLIER CODE _____ (S) BURRS AND SHARP EDGES TO BE REMOVED</p> <p>UNSPECIFIED TOLERANCES NO DECIMALS ± 1mm ONE ± 0.5mm TWO ± 0.2mm ANGULAR ± 0° - 3'</p>

DISPOSITION
0 - USE WITHOUT DISSENTANCE
1 - MODIFY STOCK
2 - SCRAP STOCK